

Lead Free Static Balancing Valve

Series: W-STBV-WM-LF

Size: DN15-DN50

The Series W-STBV-WM-LF static balancing valves are designed for flow balancing in cooling, heating or process water systems. Its measuring points enable convenient system troubleshooting. The valve features Lead Free construction to comply with Lead Free installation requirements. This product meets the lead-free requirements of NCC volume 3..

KEY FEATURES

- Accurate flow control
- Numerical indicator of opening degree on the hand wheel
- Lockable set position
- Shut-off function for troubleshooting or maintenance
- Self-sealing measuring points to protect against leakage
- Nonrising-stem
- 'Lead Free' brass body construction

CERTIFICATE

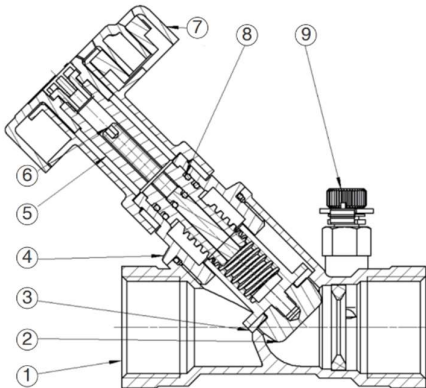

PRODUCT CODES

W-STBV-015-WM-LF	15MM LEAD FREE STATIC BALANCING VALVE PN25 WATERMARKED
W-STBV-020-WM-LF	20MM LEAD FREE STATIC BALANCING VALVE PN25 WATERMARKED
W-STBV-025-WM-LF	25MM LEAD FREE STATIC BALANCING VALVE PN25 WATERMARKED
W-STBV-032-WM-LF	32MM LEAD FREE STATIC BALANCING VALVE PN25 WATERMARKED
W-STBV-040-WM-LF	40MM LEAD FREE STATIC BALANCING VALVE PN25 WATERMARKED
W-STBV-050-WM-LF	50MM LEAD FREE STATIC BALANCING VALVE PN25 WATERMARKED

TECHNICAL DATA

Minimum Operating Temperature	-10°C
Maximum Operating Temperature	120°C
Nominal Pressure	PN25
Test Pressure - Pneumatic	Shell: 6 bar (600kPa)
Test Pressure - Hydraulic	Shell: 37.5 bar(3750kPa)
Connection Standard	ISO 7-1
Working Medium	Non corrosive liquids
1- Body Material	'Lead Free' Brass

2- Core Material	'Lead Free' Brass
3- Valve Base Sealing	PTFE
4- Bonnet Material	'Lead Free' Brass
5- Stem Material	'Lead Free' Brass
6- Core Rod Material	'Lead Free' Brass
7- Hand wheel Material	ABS Plastic
8- Shaft Sealing Material	EPDM O-ring
9- Measuring Orifices Material	'Lead Free' Brass

Lead Free Static Balancing Valve

Series: W-STBV-WM-LF

Size: DN15-DN50

DIMENSION DATA

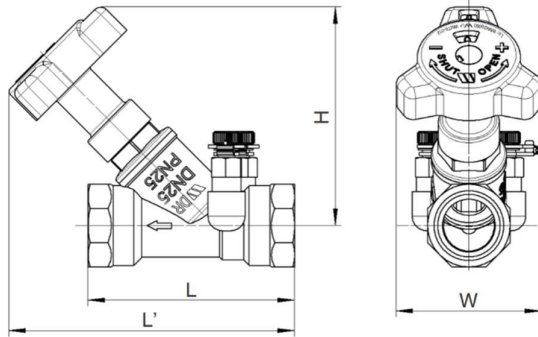

Size	L(mm)	L'(mm)	H(mm)	W(mm)	Weight(Kg)
DN15	85	133	103.5	70.3	0.49
DN20	85	133	103.5	70.3	0.54
DN25	100	141	107.5	70.3	0.71
DN32	115	154	116.0	70.3	0.97
DN40	120	157	120.0	70.3	1.23
DN50	140	174	131.0	70.3	1.70

CHARACTERISTIC CURVES

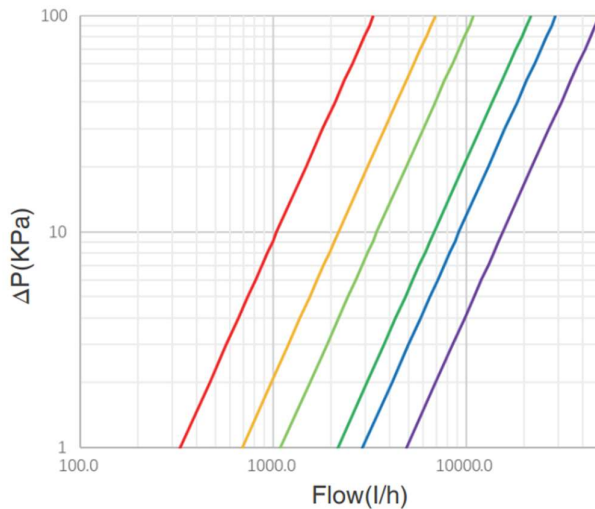

Measuring:

The flow through STBV-WM-LF valve can be measured by measuring instruments. The instruments are using this formula:

$$Q = Kvs \cdot \sqrt{\Delta p}$$

Kvs is fixed orifice flow coefficient

Δp is measured across the measuring orifices

- DN15 Kvs 3.3
- DN20 Kvs 6.9
- DN25 Kvs 10.9
- DN32 Kvs 21.6
- DN40 Kvs 29
- DN50 Kvs 49

Code	Size	Kvs (Total Valve)	Kvs (Fixed Orifice)
STBV-015-WM-LF	DN15	2.6	3.3
STBV-020-WM-LF	DN20	4.7	6.9
STBV-025-WM-LF	DN25	7.5	10.9
STBV-032-WM-LF	DN32	12.9	21.6
STBV-040-WM-LF	DN40	18.5	29.0
STBV-050-WM-LF	DN50	28.8	49.0

TYPICAL INSTALLATION

The static balancing valve is normally installed on the return pipe, When it is used with the differential pressure balancing valve valve, the static balancing valve is installed on the supply pipe.

When it is connected with elbow, a minimum of 5 pipe diameters of straight pipe upstream, a minimum of 2 pipe diameters of straight pipe downstream are required.

When it is connected with pump, a minimum of 10 pipe diameters of straight pipe upstream, a minimum of 2 pipe diameters of straight pipe downstream are required.

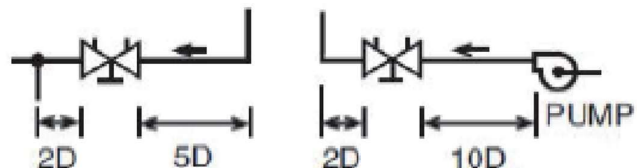

Every care has been taken in the preparation of these instructions, which have been issued as a guide only. Compliance with the requirements of local Authorities is required at all times. These requirements may change from time to time. Always be aware of the local requirements. Subject to any statutory obligations and manufacturers warranties no liability can be accepted for any losses, consequential or otherwise which may arise or be said to have arisen from relying upon the contents of this information as to the fitness of any particular product for any particular purpose, use or application. Watts Australia Pty Ltd reserves the right to modify designs and specifications and to withdraw and introduce products at any time without notice.